

# AQUAVISTA

EAST BAYSIDE, TORONTO ONTARIO

## 11 X 17 DETAIL DRAWING LIST

	10 ISSUED FOR CONSTRUCTION 17.06.19	11 SITE INSTRUCTION #01 17.07.18	18 SITE INSTRUCTION #08 18.06.20				
INTERIOR DESIGN 11 x 17 DRAWING PACKAGE							
D3.00.0 FURNITURE COVER PAGE		●	●				
D3.01.0 RESERVED							
D3.02.0 L1 WEST LOBBY CONSOLE TABLE (F.1)		●	●				
D3.03.0 L1 WEST LOBBY CONSOLE TABLE (F.4)		●	●				
D3.04.0 L1 WEST LOBBY SECTIONAL SOFA (F.5)		●	●				
D3.04.1 L1 WEST LOBBY SECTIONAL SOFA (F.5)		●	●				
D3.05.0 RESERVED							
D3.06.0 RESERVED		●					
D3.06.1 RESERVED		●					
D3.07.0 L2 AMENITY LOUNGE SECTIONAL SOFA (F.24)		●					
D3.07.1 L2 AMENITY LOUNGE SECTIONAL SOFA (F.24)		●					
D3.07.2 L2 AMENITY LOUNGE SECTIONAL SOFA (F.24)		●	●				
D3.08.0 L2 AMENITY LOUNGE SOFA (F.34)		●					
D3.08.1 L2 AMENITY LOUNGE SOFA (F.34)		●	●				
D3.09.0 L2 AMENITY LOUNGE COFFEE TABLE (F.26)		●					
D3.09.1 L2 AMENITY LOUNGE COFFEE TABLE (F.26)		●					
D3.10.0 L2 AMENITY LOUNGE CONSOLE TABLE (F.35)		●					
D3.10.1 L2 AMENITY LOUNGE CONSOLE TABLE (F.35)		●					
D3.11.0 L2 DINING ROOM DINING TABLE (F.38)		●	●				
D3.11.1 L2 DINING ROOM DINING TABLE (F.38)		●	●				
D3.12.0 P1 THEATRE LOUNGE CHAIR (F.43)		●					
D3.12.1 P1 THEATRE LOUNGE CHAIR (F.43)		●	●				
D3.13.0 P1 THEATRE SOFA (F.45)		●					
D3.13.1 P1 THEATRE SOFA (F.45)		●					
D3.14.0 CUSTOM CUSHIONS (F.9A)			●				
D3.15.0 L2-L12 WEST ELEVATOR LOBBY BENCH (F.41)		●	●				
D3.15.1 L2-L12 EAST ELEVATOR LOBBY BENCH (F.42)		●	●				
D3.16.0 L2 BILLIARDS ROOM SOFA (F.69)			●				
D3.16.1 L2 BILLIARDS ROOM SOFA (F.69)			●				
D3.17.0 L2 LOUNGE AREA CONSOLE TABLE (F.76)			●				
TOTAL DRAWINGS ISSUED:	0	22	16				

**Notes:**

- CONTRACTOR AND ALL SUB-TRADES SHALL VERIFY ALL SITE DIMENSIONS, ALL DRAWINGS, DETAILS AND SPECIFICATIONS AND REPORT ANY DISCREPANCIES TO THE INTERIOR DESIGNERS IN WRITING FOR APPROVAL BEFORE PROCEEDING WITH THE WORK.
- CONTRACTOR AND SUB-CONTRACTORS, BEFORE PROCEEDING WITH WORK, MUST SUBMIT ALL NECESSARY SAMPLES FOR APPROVAL OF QUALITY AND FINISH TO THE INTERIOR DESIGNER.
- CONTRACTOR MUST COMPLY WITH THE CONTRACT DOCUMENTS, PERFORMANCE REQUIREMENTS, APPLICABLE CODES AND REGULATIONS.
- ALL DRAWINGS AND WRITTEN MATERIAL HEREIN CONSTITUTES THE ORIGINAL AND UNPUBLISHED WORK OF " II BY IV DESIGN ASSOCIATES INC. ", AND MAY NOT BE DUPLICATED, USED OR DISCLOSED WITHOUT PRIOR WRITTEN CONSENT OF " II BY IV DESIGN ASSOCIATES INC. "
- DRAWINGS NOT TO BE SCALED

**Issue:**

11 SITE INSTRUCTION #01	17.07.18
18 SITE INSTRUCTION #08	18.06.20
-	-
-	-
-	-
-	-
-	-
-	-
-	-
-	-
-	-
-	-
-	-
-	-

Hines TRIDEL®

AQUAVISTA  
AT BAYSIDE TORONTO

255 QUEEN'S QUAY EAST, TORONTO ONTARIO

77 MOWAT AVENUE, SUITE 109  
TORONTO, ONTARIO M6K 3E3 - CANADA  
T + 1 416 531 2224

12 DESBROSSES STREET  
NEW YORK, NEW YORK 10013 - USA  
T + 1 212 392 4952



Drawing Title:

FURNITURE  
COVER PAGE

Our Project Number:  
14008

Designed By: DM,KR,XX      Detailed By: DM,KR,XX,XX

Drawing Number:

D3.00.0



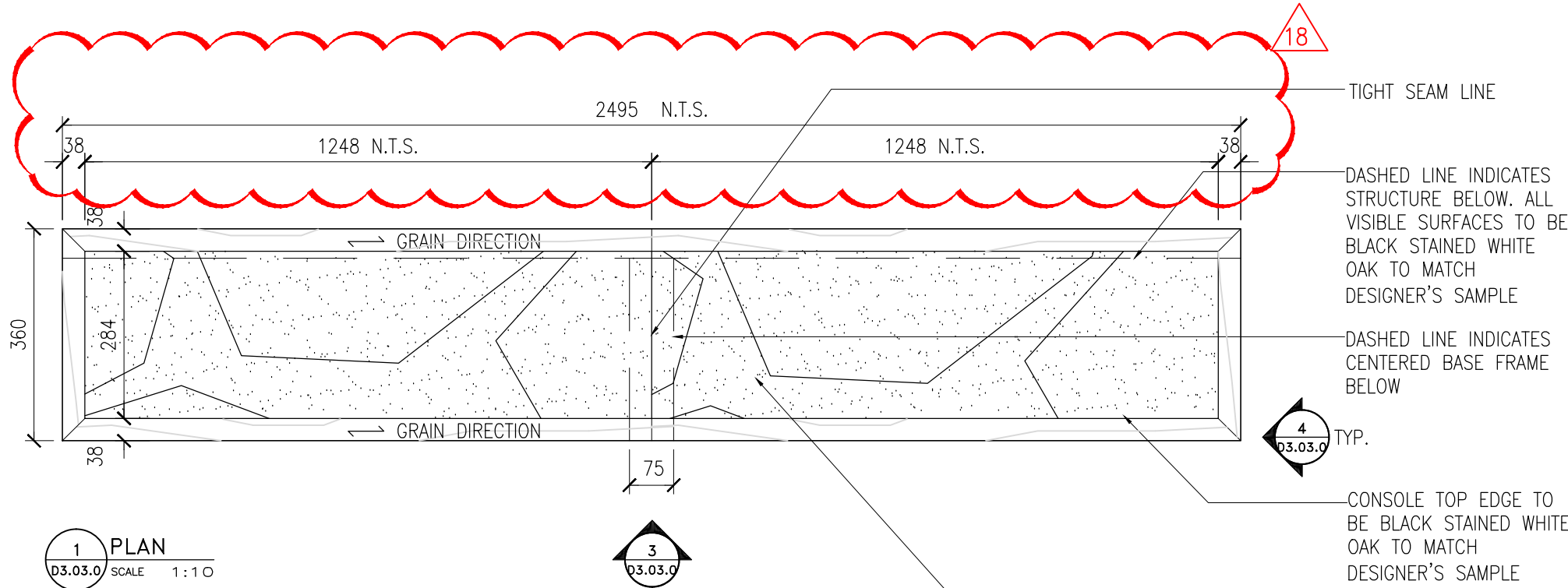

RECESSED 20MM THK. STONE TOP TO SIT PROUD OF WOOD TOP BY 10 MM;  
OLYMPIA TILE, ELEGANT BLACK, BRUSHED

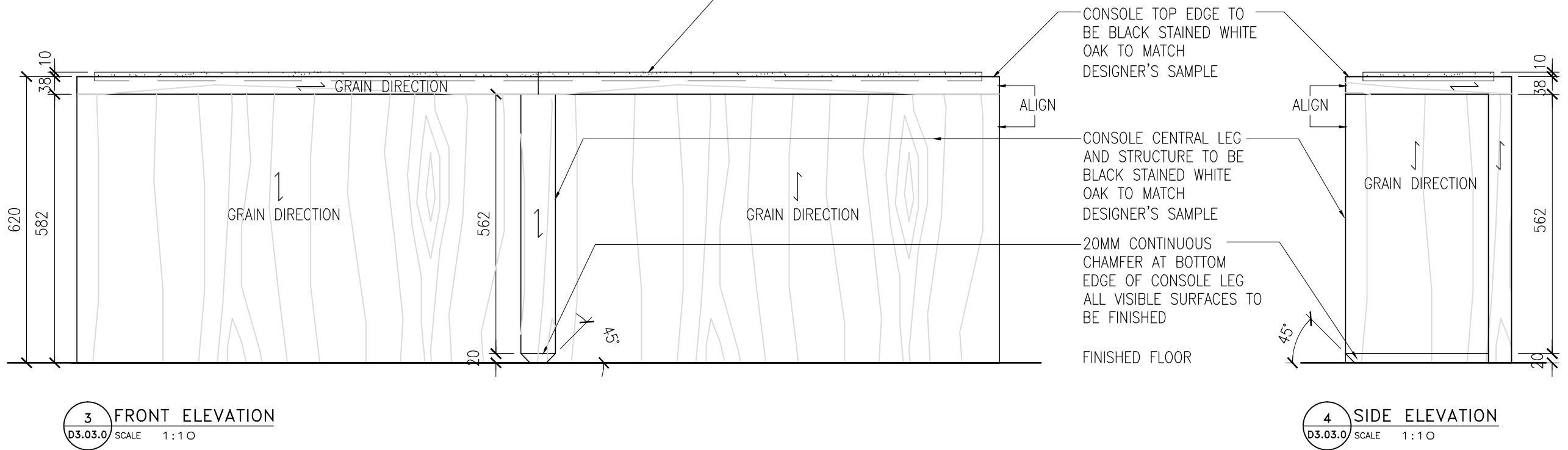

<b>Quantity</b>	<b>1</b>
-----------------	----------

Notes:

- FABRICATOR TO CONFIRM QUANTITIES OF FIXTURES WITH CLIENT PRIOR TO FABRICATION
- PROVIDE SHOP DRAWINGS FOR DESIGNER'S REVIEW AND APPROVAL PRIOR TO FABRICATION
- FABRICATOR TO ENSURE STRUCTURAL STABILITY OF UNIT
- FABRICATOR TO EXECUTE DESIGN IN THE MOST COST EFFECTIVE MANNER
- FABRICATOR TO PROVIDE FINISH SAMPLES FOR DESIGNER'S REVIEW AND APPROVAL PRIOR TO FABRICATION
- ALL EXPOSED EDGES TO BE FINISHED TO MATCH SURFACE (POLISHED OR BRUSHED).

- 18
- CONTRACTOR AND ALL SUB-TRADES SHALL VERIFY ALL SITE DIMENSIONS, ALL DRAWINGS, DETAILS AND SPECIFICATIONS AND REPORT ANY DISCREPANCIES TO THE INTERIOR DESIGNERS IN WRITING FOR APPROVAL BEFORE PROCEEDING WITH THE WORK.
  - CONTRACTOR AND SUB-CONTRACTORS, BEFORE PROCEEDING WITH WORK, MUST SUBMIT ALL NECESSARY SAMPLES FOR APPROVAL OF QUALITY AND FINISH TO THE INTERIOR DESIGNER.
  - CONTRACTOR MUST COMPLY WITH THE CONTRACT DOCUMENTS, PERFORMANCE REQUIREMENTS, APPLICABLE CODES AND REGULATIONS.
  - ALL DRAWINGS AND WRITTEN MATERIAL HEREIN CONSTITUTES THE ORIGINAL AND UNPUBLISHED WORK OF "II BY IV DESIGN ASSOCIATES INC.", AND MAY NOT BE DUPLICATED, USED OR DISCLOSED WITHOUT PRIOR WRITTEN CONSENT OF "II BY IV DESIGN ASSOCIATES INC."
  - DRAWINGS NOT TO BE SCALED

Issue:

11 SITE INSTRUCTION #01	17.07.18
18 SITE INSTRUCTION #08	18.06.20
-	-
-	-
-	-
-	-
-	-
-	-
-	-
-	-
-	-
-	-
-	-
-	-
-	-

Hines TRIDEL®

AQUAVISTA  
AT BAYSIDE TORONTO

255 QUEEN'S QUAY EAST, TORONTO ONTARIO

77 MOWAT AVENUE, SUITE 109  
TORONTO, ONTARIO M6K 3E3 - CANADA  
T + 1 416 531 2224

12 DESBROSSES STREET  
NEW YORK, NEW YORK 10013 - USA  
T + 1 212 392 4952

II BY IV DESIGN

Drawing Title:  
**L1 WEST LOBBY  
CONSOLE TABLE (F.4)**

Our Project Number:  
14008

Designed By:  
DM, KR, XX

Detailed By:  
DM, KR, XX, XX

Drawing Number:

**D3.03.0**











Quantity	1
<b>Notes:</b>	
1.	FABRICATOR TO CONFIRM QUANTITIES OF FIXTURES WITH CLIENT PRIOR TO FABRICATION
2.	PROVIDE SHOP DRAWINGS FOR DESIGNER'S REVIEW AND APPROVAL PRIOR TO FABRICATION
3.	FABRICATOR TO ENSURE STRUCTURAL STABILITY OF UNIT
4.	FABRICATOR TO EXECUTE DESIGN IN THE MOST COST EFFECTIVE MANNER
5.	ALL METAL TO BE GROUND SMOOTH, NO SHARP EDGES
6.	FABRICATOR TO PROVIDE CONCEALED SUPPORT - NO SAGGING

- Notes:**
- CONTRACTOR AND ALL SUB-TRADES SHALL VERIFY ALL SITE DIMENSIONS. ALL DRAWINGS, DETAILS AND SPECIFICATIONS AND REPORT ANY DISCREPANCIES TO THE INTERIOR DESIGNERS IN WRITING FOR APPROVAL BEFORE PROCEEDING WITH THE WORK.
  - CONTRACTOR AND SUB-CONTRACTORS, BEFORE PROCEEDING WITH WORK, MUST SUBMIT ALL NECESSARY SAMPLES FOR APPROVAL OF QUALITY AND FINISH TO THE INTERIOR DESIGNER.
  - CONTRACTOR MUST COMPLY WITH THE CONTRACT DOCUMENTS, PERFORMANCE REQUIREMENTS, APPLICABLE CODES AND REGULATIONS.
  - ALL DRAWINGS AND WRITTEN MATERIAL HEREIN CONSTITUTES THE ORIGINAL AND UNPUBLISHED WORK OF "II BY IV DESIGN ASSOCIATES INC.", AND MAY NOT BE DUPLICATED, USED OR DISCLOSED WITHOUT PRIOR WRITTEN CONSENT OF "II BY IV DESIGN ASSOCIATES INC."
  - DRAWINGS NOT TO BE SCALED

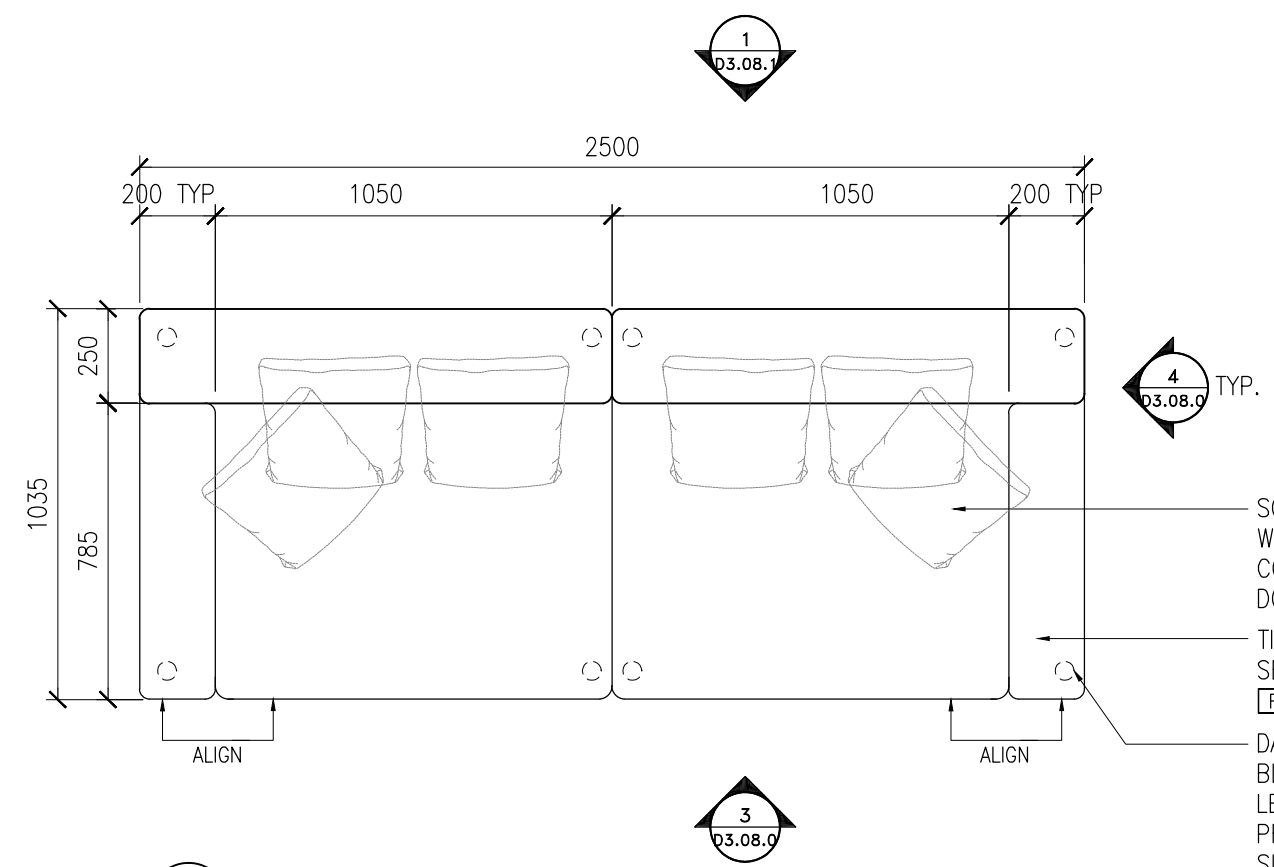

**1 PLAN**  
D3.08.0 SCALE 1:20

SOFA SEAT CUSHION TO BE WRAPPED HIGH DENSITY COMMERCIAL GRADE FOAM WITH DOWN TOP

TIGHTLY UPHOLSTERED SOFA SEAT, ARM AND BACK

DASHED LINE INDICATES MATTE BLACK POWDER COAT METAL LEGS BELOW  
PROVIDE ADDITIONAL FRAME SUPPORT AS REQUIRED



**2 REFERENCE IMAGE**  
D3.08.0 SCALE N.T.S

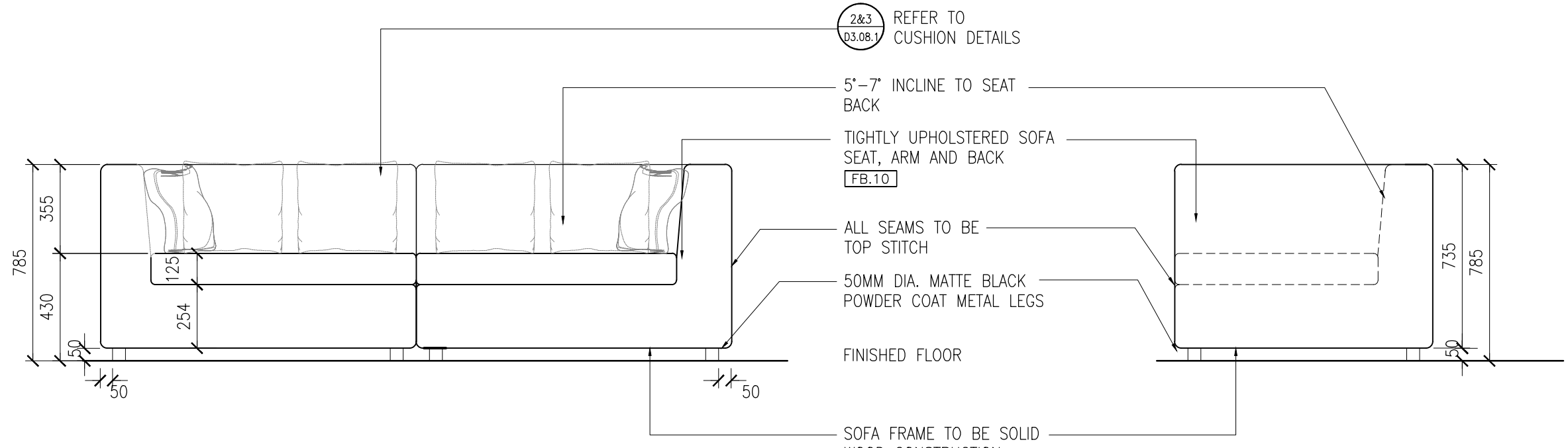

**3 ELEVATION**  
D3.08.0 SCALE 1:20

**4 ELEVATION**  
D3.08.0 SCALE 1:20

Hines TRIDEL

AQUAVISTA  
AT BAYSIDE TORONTO

255 QUEEN'S QUAY EAST, TORONTO ONTARIO

77 MOWAT AVENUE, SUITE 109  
TORONTO, ONTARIO M6K 3E3 - CANADA  
T + 1 416 531 2224

12 DESBROSSES STREET  
NEW YORK, NEW YORK 10013 - USA  
T + 1 212 392 4952



Drawing Title:  
**L2 LOUNGE AREA  
SOFA (F.34)**

Our Project Number:  
14008

Designed By: DM,KR,XX      Detailed By: DM,KR,XX,XX

Drawing Number:

**D3.08.0**





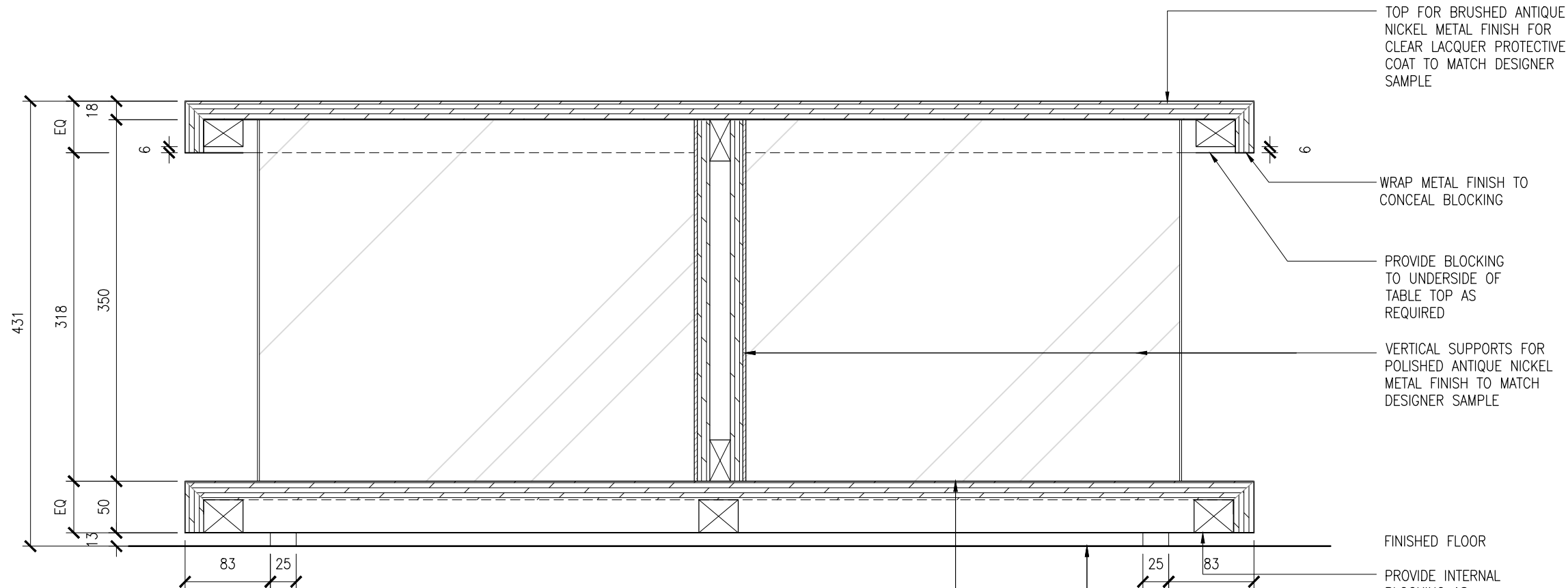

**1 DETAILED SECTION**  
D3.09.1 SCALE 1:5

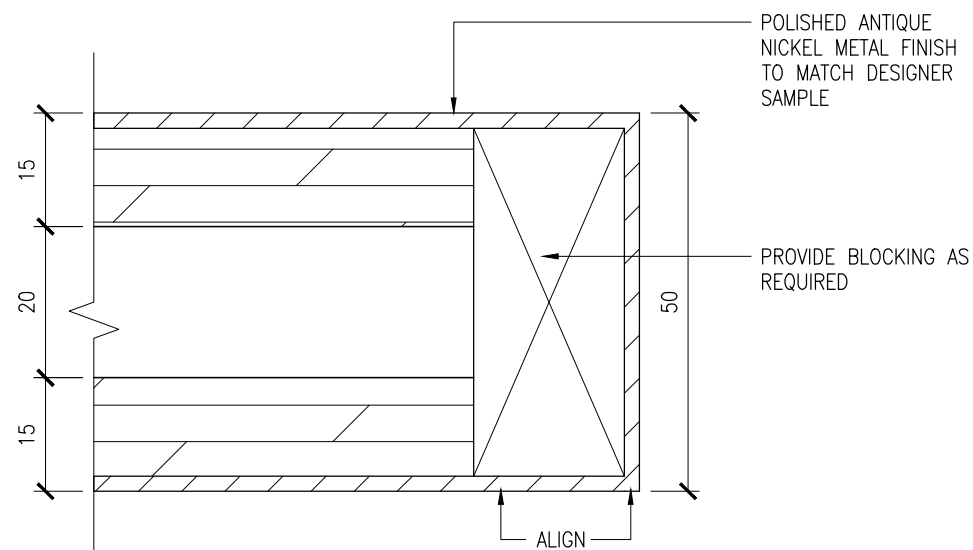

**2 TABLE BASE HORIZONTAL DETAIL**  
D3.09.1 SCALE 1:1

Quantity	1
<b>Notes:</b>	
1.	FABRICATOR TO CONFIRM QUANTITIES OF FIXTURES WITH CLIENT PRIOR TO FABRICATION
2.	PROVIDE SHOP DRAWINGS FOR DESIGNER'S REVIEW AND APPROVAL PRIOR TO FABRICATION
3.	FABRICATOR TO ENSURE STRUCTURAL STABILITY OF UNIT
4.	FABRICATOR TO EXECUTE STRUCTURE IN THE MOST COST EFFECTIVE MANNER
5.	ALL METAL TO BE GROUND SMOOTH AND CLEAN - NO SHARP EDGES
6.	ENSURE TABLE IS LEVEL

- Notes:**
- CONTRACTOR AND ALL SUB-TRADES SHALL VERIFY ALL SITE DIMENSIONS, ALL DRAWINGS, DETAILS AND SPECIFICATIONS AND REPORT ANY DISCREPANCIES TO THE INTERIOR DESIGNERS IN WRITING FOR APPROVAL BEFORE PROCEEDING WITH THE WORK.
  - CONTRACTOR AND SUB-CONTRACTORS, BEFORE PROCEEDING WITH WORK, MUST SUBMIT ALL NECESSARY SAMPLES FOR APPROVAL OF QUALITY AND FINISH TO THE INTERIOR DESIGNER.
  - CONTRACTOR MUST COMPLY WITH THE CONTRACT DOCUMENTS, PERFORMANCE REQUIREMENTS, APPLICABLE CODES AND REGULATIONS.
  - ALL DRAWINGS AND WRITTEN MATERIAL HEREIN CONSTITUTES THE ORIGINAL AND UNPUBLISHED WORK OF "II BY IV DESIGN ASSOCIATES INC.", AND MAY NOT BE DUPLICATED, USED OR DISCLOSED WITHOUT PRIOR WRITTEN CONSENT OF "II BY IV DESIGN ASSOCIATES INC."
  - DRAWINGS NOT TO BE SCALED

**Issue:**

Issue #	Description	Date
11	SITE INSTRUCTION #01	17.07.18
-	-	-
-	-	-
-	-	-
-	-	-
-	-	-
-	-	-
-	-	-
-	-	-
-	-	-
-	-	-

Hines TRIDEL

AQUAVISTA  
AT BAYSIDE TORONTO

255 QUEEN'S QUAY EAST, TORONTO ONTARIO

77 MOWAT AVENUE, SUITE 109  
TORONTO, ONTARIO M6K 3E3 - CANADA  
T + 1 416 531 2224

12 DESBROSSES STREET  
NEW YORK, NEW YORK 10013 - USA  
T + 1 212 392 4952



**Drawing Title:**  
L2 LOUNGE AREA  
COFFEE TABLE (F.26)

**Our Project Number:**  
14008

**Designed By:** DM, KR, XX **Detailed By:** DM, KR, XX, XX

**Drawing Number:**

D3.09.1













Quantity	1
<b>Notes:</b>	
1.	FABRICATOR TO CONFIRM QUANTITIES OF FIXTURES WITH CLIENT PRIOR TO FABRICATION
2.	PROVIDE SHOP DRAWINGS FOR DESIGNER'S REVIEW AND APPROVAL PRIOR TO FABRICATION
3.	FABRICATOR TO ENSURE STRUCTURAL STABILITY OF UNIT
4.	FABRICATOR TO EXECUTE DESIGN IN THE MOST COST EFFECTIVE MANNER
5.	ALL METAL TO BE GROUND SMOOTH, NO SHARP EDGES
6.	FABRICATOR TO PROVIDE CONCEALED SUPPORT - NO SAGGING

- Notes:**
- CONTRACTOR AND ALL SUB-TRADES SHALL VERIFY ALL SITE DIMENSIONS. ALL DRAWINGS, DETAILS AND SPECIFICATIONS AND REPORT ANY DISCREPANCIES TO THE INTERIOR DESIGNERS IN WRITING FOR APPROVAL BEFORE PROCEEDING WITH THE WORK.
  - CONTRACTOR AND SUB-CONTRACTORS, BEFORE PROCEEDING WITH WORK, MUST SUBMIT ALL NECESSARY SAMPLES FOR APPROVAL OF QUALITY AND FINISH TO THE INTERIOR DESIGNER.
  - CONTRACTOR MUST COMPLY WITH THE CONTRACT DOCUMENTS, PERFORMANCE REQUIREMENTS, APPLICABLE CODES AND REGULATIONS.
  - ALL DRAWINGS AND WRITTEN MATERIAL HEREIN CONSTITUTES THE ORIGINAL AND UNPUBLISHED WORK OF "II BY IV DESIGN ASSOCIATES INC.", AND MAY NOT BE DUPLICATED, USED OR DISCLOSED WITHOUT PRIOR WRITTEN CONSENT OF "II BY IV DESIGN ASSOCIATES INC."
  - DRAWINGS NOT TO BE SCALED

**Issue:**

11 SITE INSTRUCTION #01	17.07.18
18 SITE INSTRUCTION #08	18.06.20
-	-
-	-
-	-
-	-
-	-
-	-
-	-
-	-
-	-
-	-
-	-
-	-
-	-

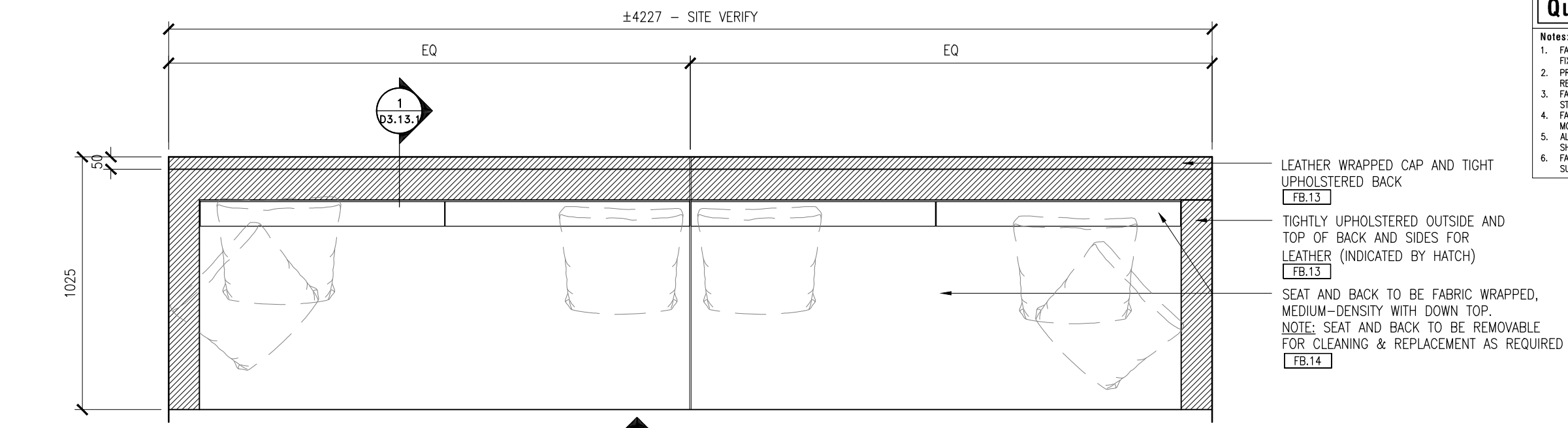

**1 PLAN**  
D3.13.0 SCALE 1:20 QTY: 1

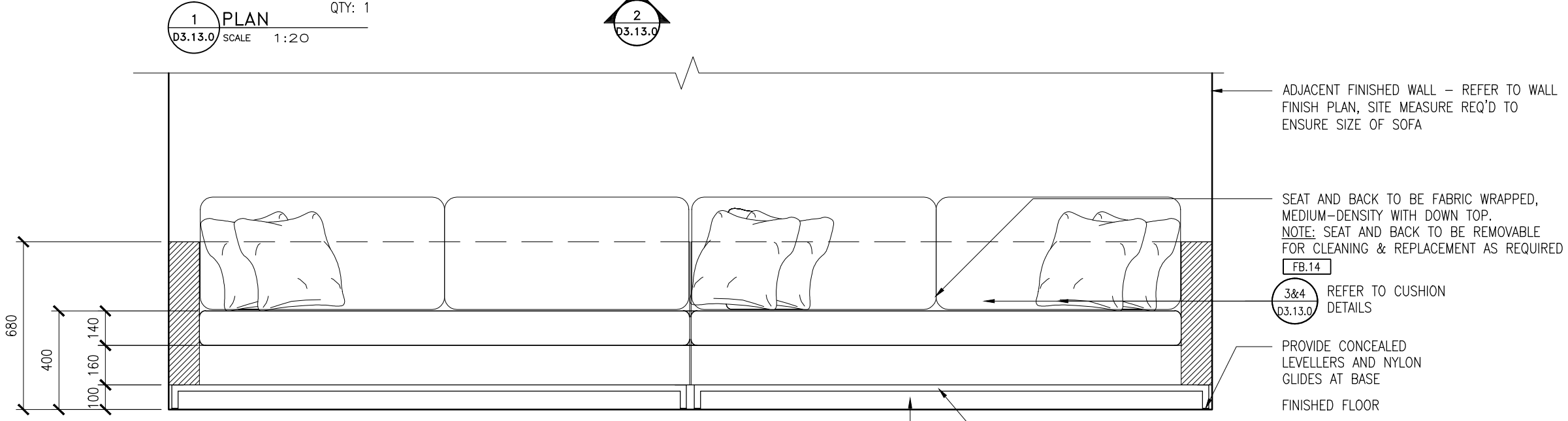

**2 ELEVATION**  
D3.13.0 SCALE 1:20

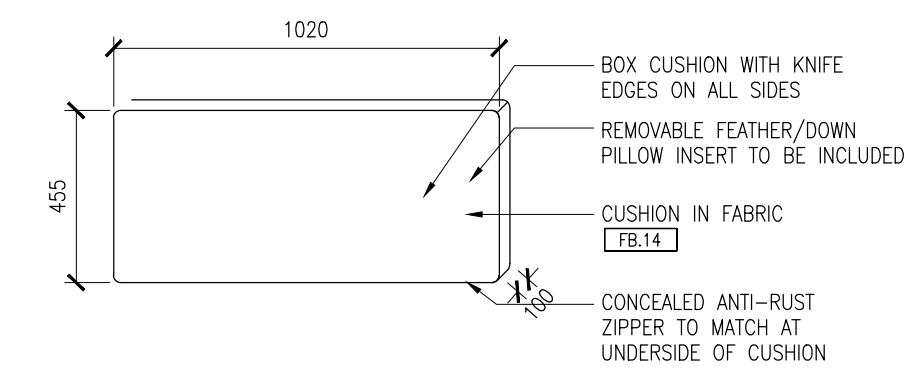

**3 LARGE BOX CUSHION ELEVATION**  
D3.13.0 SCALE 1:20 QTY: 4

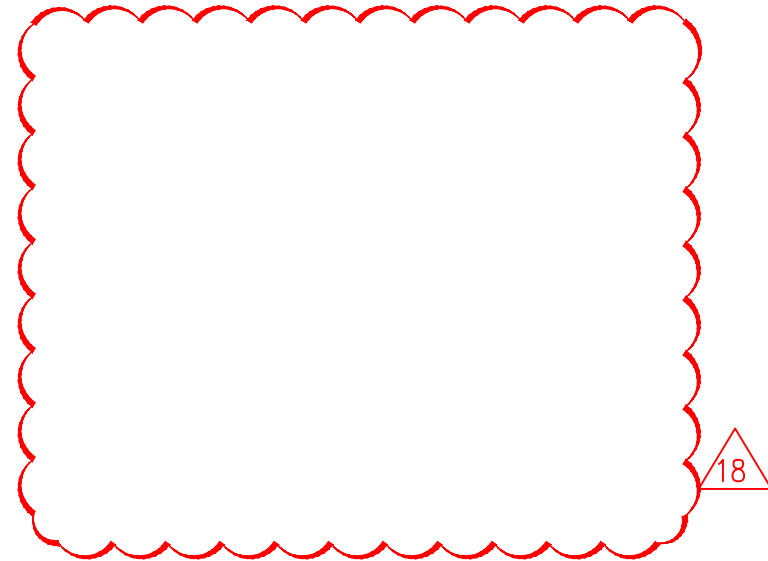

Hines TRIDEL®

AQUAVISTA  
AT BAYSIDE TORONTO

255 QUEEN'S QUAY EAST, TORONTO ONTARIO

77 MOWAT AVENUE, SUITE 109  
TORONTO, ONTARIO M6K 3E3 - CANADA  
T + 1 416 531 2224

12 DESBROSSES STREET  
NEW YORK, NEW YORK 10013 - USA  
T + 1 212 392 4952



Drawing Title:  
**P1 THEATRE SOFA (F.45)**

Our Project Number:  
14008

Designed By: DM,KR,XX Detailed By: DM,KR,XX,XX

Drawing Number:

**D3.13.0**



<b>Quantity</b>	N/A
<b>Notes:</b>	
1. FABRICATOR TO CONFIRM QUANTITIES OF FIXTURES WITH CLIENT PRIOR TO FABRICATION	
2. PROVIDE SHOP DRAWINGS FOR DESIGNER'S REVIEW AND APPROVAL PRIOR TO FABRICATION	
3. FABRICATOR TO EXECUTE DESIGN IN THE MOST COST EFFECTIVE MANNER	
4. FABRICATOR TO PROVIDE FABRIC CUTTING FOR REVIEW AND APPROVAL OF DIE LOT PRIOR TO ORDERING.	

- Notes:**
1. CONTRACTOR AND ALL SUB-TRADES SHALL VERIFY ALL SITE DIMENSIONS. ALL DRAWINGS, DETAILS AND SPECIFICATIONS AND REPORT ANY DISCREPANCIES TO THE INTERIOR DESIGNERS IN WRITING FOR APPROVAL BEFORE PROCEEDING WITH THE WORK.
  2. CONTRACTOR AND SUB-CONTRACTORS, BEFORE PROCEEDING WITH WORK, MUST SUBMIT ALL NECESSARY SAMPLES FOR APPROVAL OF QUALITY AND FINISH TO THE INTERIOR DESIGNER.
  3. CONTRACTOR MUST COMPLY WITH THE CONTRACT DOCUMENTS, PERFORMANCE REQUIREMENTS, APPLICABLE CODES AND REGULATIONS.
  4. ALL DRAWINGS AND WRITTEN MATERIAL HEREIN CONSTITUTES THE ORIGINAL AND UNPUBLISHED WORK OF " II BY IV DESIGN ASSOCIATES INC. ", AND MAY NOT BE DUPLICATED, USED OR DISCLOSED WITHOUT PRIOR WRITTEN CONSENT OF " II BY IV DESIGN ASSOCIATES INC. "
  5. DRAWINGS NOT TO BE SCALED

**Issue:**

18 SITE INSTRUCTION #08	18.06.20
-	-
-	-
-	-
-	-
-	-
-	-
-	-
-	-
-	-
-	-
-	-
-	-
-	-
-	-

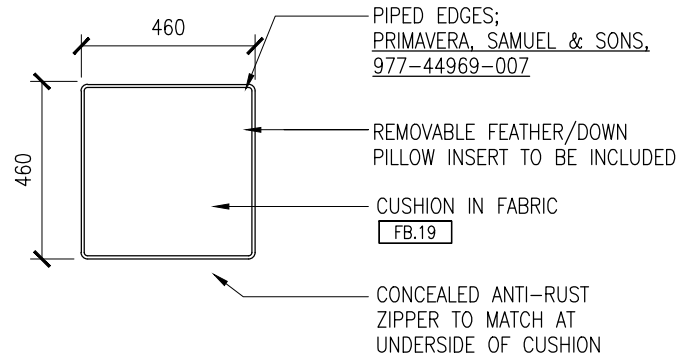

**1** SMALL CUSHION (F.9A)  
 D3.14.0 SCALE 1:20 QTY. 6

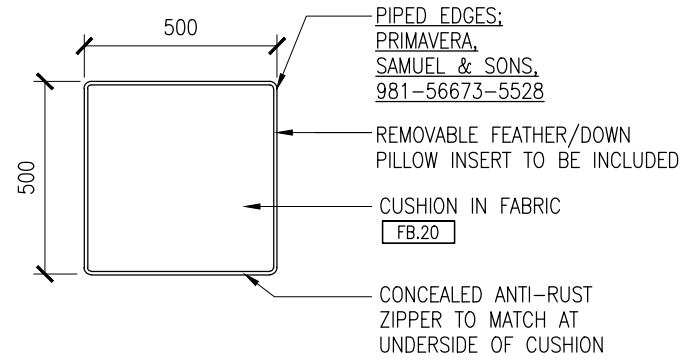

**2** SMALL CUSHION (F.67A)  
 D3.14.0 SCALE 1:20 QTY. 2

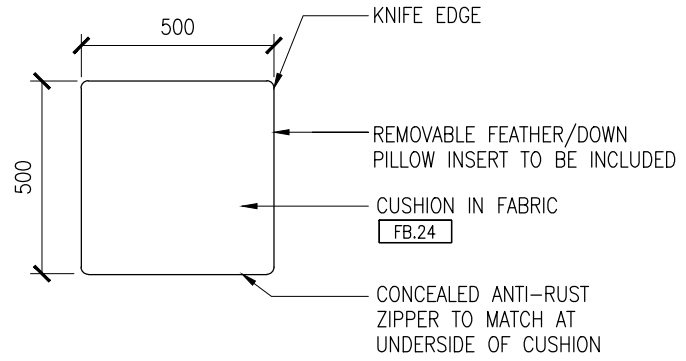

**3** SMALL CUSHION (F.68A)  
 D3.14.0 SCALE 1:20 QTY. 1

Hines TRIDEL®

AQUAVISTA  
 AT BAYSIDE TORONTO

255 QUEEN'S QUAY EAST, TORONTO ONTARIO

77 MOWAT AVENUE, SUITE 109  
 TORONTO, ONTARIO M6K 3E3 - CANADA  
 T + 1 416 531 2224  
 12 DESBROSSES STREET  
 NEW YORK, NEW YORK 10013 - USA  
 T + 1 212 392 4952



**Drawing Title:**  
 SMALL CUSHION (F.9A)  
 SMALL CUSHION (F.67A)

**Our Project Number:**  
 14008  
**Designed By:** DM,KR,XX **Detailed By:** DM,KR,XX,XX  
**Drawing Number:**

D3.14.0









