

- HOT TUB KEY NOTES:**
- PROVIDE TELEPHONE AS PER CBC 3.10.1 (b) AND SHALL BE INSTALLED WITHIN 30m OF THE POOL.
  - ALL RECIRCULATING PUMPS SHALL BE CAPABLE OF BEING DEACTIVATED BY AN EMERGENCY STOP BUTTON. CLEARLY LABELED AND LOCATED ON THE DECK AREA.
  - AN EMERGENCY SIGN CONTAINING THE WORDS "IN THE EVENT OF AN EMERGENCY, PUSH EMERGENCY STOP BUTTON AND USE EMERGENCY PHONE, AUDIBLE AND VISUAL SIGNAL WILL ACTIVATE" SHALL BE IN LETTERS AT LEAST 25mm HIGH WITH A 5mm STROBE. POST THE SIGN ABOVE THE EMERGENCY STOP BUTTON.
  - DIV. 16 TO PROVIDE 100A, 3P DISCONNECT IN POOL MECHANICAL ROOM FOR TURN-KEY POOL CONTRACTOR'S USE.
  - EXACT LOCATIONS OF OUTLETS TO BE DETERMINED ON SITE.
  - THIS LAYOUT AND CIRCUITING, ARE FOR INFORMATION ONLY. CONTRACTOR SHALL CONFIRM WITH SHOP DRAWINGS FOR FINAL EQUIPMENT LAYOUT AND QUANTITY.
  - EMERGENCY LIGHT FIXTURES IN LOCKERS, STORAGE, GARBAGE, UTILITY AND SERVICE ROOMS SHALL BE CONNECTED TO BOTH NORMAL AND EMERGENCY POWER AS PER DETAIL #1 OF DUG. E-35.

- HOT TUB EQUIPMENTS:**
- JET PUMP  
575V, 3P, 3HP  
CCT. FROM (FP-F)
  - FILTER PUMP  
575V, 3P, 3/4HP  
CCT. FROM (FP-F)
  - CHEMICAL CONTROLLER  
120V, 1P, 15A  
CCT. (P-2)
  - WATER LEVEL CONTROL SYSTEM  
120V, 1P, 15A  
CCT. (P-4)
  - HYDROTHERAPY BOOSTER PUMP  
575V, 3P, 3HP  
CONN. TO FP-F
  - TUB ACID FEED PUMP  
120V, 1P  
CONN. TO P-3
  - ELECTRIC HEATER  
575V, 3P, 15KW  
CONN. TO FP-F

**GENERAL AREA CIRCUITING - TABLE #1**

LIGHTING FIXTURE LOCATION	CCT.*
P2 TO P1 - EXIT SIGNS	E-1
G/F TO MPH - EXIT SIGNS	E-3
MPH - EXIT SIGNS	ER-1
STAIR 'A' (P2 TO G/F)	E-5
STAIR 'B' (P2 TO G/F)	E-1
STAIR 'J' (G/F TO 4/F)	E-9
STAIR 'J' (5/F TO 9/F)	E-11
STAIR 'G' (G/F TO 14/F)	E-13
STAIR 'F' (G/F TO 14/F)	E-15
STAIR 'K' (14/F TO MPH) & MPH (G/F)	ER-3ER-5R-1TR-1B E-2E-4E-6E-16E-8E-10E-12E-14E-16
(G/F)	B1-2B1-4B1-6B1-8B1-10B1-12B1-14B1-16B1-18B1-20B1-22B1-24B1-26B1-28B1-30
CORRIDOR (2/F & 3/F)	E-24
CORRIDOR (4/F & 5/F)	E-26
CORRIDOR (6/F & 7/F)	E-28
CORRIDOR (8/F TO 11/F)	E-30
CORRIDOR (12/F TO 14/F)	E-32
CORRIDOR & LOCKER (2/F)	B-46
CORRIDOR (3/F)	B-48
CORRIDOR (4/F)	B-50
CORRIDOR (5/F & 6/F)	B-52
CORRIDOR (7/F & 8/F)	B-54
CORRIDOR (9/F TO 11/F)	B-56
CORRIDOR (12/F TO 14/F)	B-58
ELEVATOR CAB	ER-6, ER-8ER-10
EXTERIOR SITE	E1-1E1-3E1-5E1-7E1-4E1-6

- KEY NOTES - INSUITE:**
- DESIGNATED "LAUNDRY RECEPTACLE" AS DEFINED BY ESA CODE 26-1102(e)(1), 26-120(b) AND ESA BULLETIN 26-26-0 (WITHIN 3m RADIUS OF LAUNDRY CLOSET). RECEPTACLE SHALL BE CONNECTED TO A DEDICATED CIRCUIT. SEE DETAIL #4 ON DUG. E-35.
  - SUITE DOOR CONTACTS AND GLASS BREAK DETECTOR WILL COMPLETE WITH INTRUSION ALARM SYSTEM THAT CONTACT TO THE CONCIERGE STATION. (TYPICAL)
  - FOR FAN COIL UNITS (FCU) ELECTRICAL CONTRACTOR TO SUPPLY AND INSTALL CONDUIT AND JUNCTION BOX FOR REMOTE THERMOSTAT. MECHANICAL CONTRACTOR SHALL SUPPLY WIRE, TERMINATE WIRING AND MOUNT THERMOSTAT.
  - INSTALL SIDE-MOUNTED RECEPTACLE ON KITCHEN ISLAND CABINET.
  - SWITCHES, RECEPTACLES, ETC. TO BE INSTALLED AS TO NOT INTERFERE WITH THE OPENING AND OPERATION OF SLIDING DOOR.
  - TERRACE LIGHTING FIXTURE AND RECEPTACLE, SHALL BE CENTERED ON PANEL (350MM FROM CENTRE OF DOOR MULLION) REFER TO ARCHITECTURAL ELEVATION.

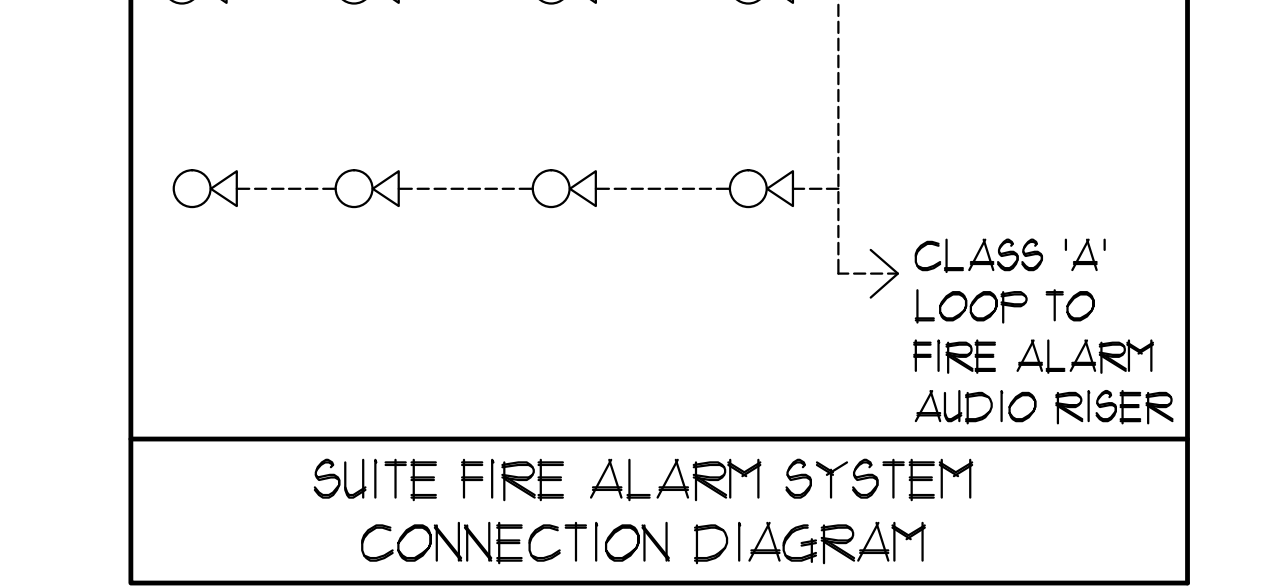

**MOUNTING HEIGHT SCHEDULE (TO TOP OF BOX)**

OUTLET	SUITE	PUBLIC AREA
RECEPTACLE	400 MM AFF.	400 MM AFF.
TV OUTLET	400 MM AFF.	400 MM AFF.
TELEPHONE OUTLET	400 MM AFF.	400 MM AFF.
MULTI-PORT OUTLET	400 MM AFF.	400 MM AFF.
SWITCH	1200 MM AFF.	1200 MM AFF.
SECURITY PANEL	1200 MM AFF.	
SILENCE SWITCHES	1200 MM AFF.	
THERMOSTAT	1200 MM AFF.	1200 MM AFF.
INTERCOM	1200 MM AFF.	
V.C. HANDSET	1200 MM AFF.	
FULL STATION	1200 MM AFF.	

- GENERAL NOTES - RESIDENTIAL:**
- ELECTRICAL DRAWINGS SHALL BE READ IN CONJUNCTION WITH MECHANICAL, STRUCTURAL, ARCHITECTURAL AND LANDSCAPE DRAWINGS.
  - CONTRACTOR SHALL RUN CABLES WITHIN CEILING SLAB OR ENCLOSURES TO RETAIN 2 HOUR FIRE PROTECTION RATING FOR ALL LOADS THAT CONNECT TO EMERGENCY POWER.
  - FIRE ALARM RISERS SHALL BE RUN IN 2 HOUR FIRE RATED ELECTRICAL CLOSET. WALL TO MOUNT DUG. E-32 FOR RISER DIAGRAM AND DETAILS.
  - STAIRWAY REFER TO DUG. E-32 FOR RISER DIAGRAM AND DETAILS.
  - EMERGENCY LIGHT FIXTURES SHALL BE MOUNTED @ 1" AFF. MIN.
  - FOR STORAGE ROOM VENTILATION SYSTEM, DIV. 16 TO PROVIDE CONDUIT, WIRING AND SWITCH (S) TO START/STOP FAN AND DAMPER. FAN AND 100V ACTUATOR TO BE SUPPLIED AND INSTALLED BY DIV. 15.
  - FOR UTILITY ROOM VENTILATION SYSTEM, DIV. 15 WILL PROVIDE LINE VOLTAGE THERMOSTAT (T) TO DIV. 16. DIV. 16 TO PROVIDE CONDUIT AND WIRING TO START/STOP FAN AND DAMPER VIA THERMOSTAT. FAN AND 100V ACTUATOR TO BE SUPPLIED AND INSTALLED BY DIV. 15.
  - FOR UNIT HEATER, DIV. 15 TO PROVIDE LINE VOLTAGE THERMOSTAT (T), DIV. 16 TO PROVIDE CONDUIT AND WIRING TO START/STOP UNIT HEATER.
  - REFER TO SPRINKLER DRAWINGS FOR FIRE PROTECTION DEVICE TO BE CONNECTED TO THE FIRE ALARM SYSTEM. THE DEVICE AND EQUIPMENT SHALL FORM AN INTEGRAL PART OF THE ELECTRICAL CONTRACT.
  - DIV. 16 SHALL SUPPLY AND INSTALL CONDUITS, WIRES AND INTERLOCK FANS TO MOTORIZED DAMPERS AND TO THE THERMOSTAT.
  - DIV. 16 SHALL SUPPLY AND INSTALL CONDUITS, WIRES AND INTERLOCK FANS TO MOTORIZED DAMPERS AND TO THE THERMOSTAT.
  - REFER TO SUITE PANEL SCHEDULES FOR INSUITE CIRCUIT ARRANGEMENT.
  - ALL DWELLING UNIT RECEPTACLES EXCEPT IN KITCHEN SHALL BE TAMPER PROOF.
  - PROVIDE GROUND FAULT PROTECTION FOR SUITE KITCHEN, AMENITY KITCHEN AND WASHROOM RECEPTACLES WITHIN 1500mm OF SINK.
  - PROVIDE TELECOMMUNICATION BOX C/W BUILT-IN RECEPTACLE FOR TELECOMMUNICATION. TELECOMMUNICATION BOX SHALL BE COMPLIANT WITH THE TELECOM SERVICE PROVIDER SPECIFICATION. REFER TO DETAIL #9 ON DUG. E-35 FOR TELECOM JUNCTION BOX INSTALLATION.
  - DRYER SENSOR TO START DRYER VENTILATION FAN AUTOMATICALLY WHEN DRYER IS RUNNING.
  - ALL SMOKE ALARMS WITHIN THE SUITE SHALL BE HARDWIRED TOGETHER AND TO A 15A, 1P CIRCUIT BREAKER AHEAD OF OTHER LOADS.
  - ALL OUTDOOR RECEPTACLES SHALL BE WEATHERPROOF (LEGRADE CAT# 332TRUR-GRY FOR NON-GFCI AND CAT# 15B5TRUR-GRY FOR GFCI) AND SHALL BE EQUIPPED WITH A WHILE IN USE CAST ALUMINUM COVERPLATE (LEGRADE CAT# WUCAST) COVERPLATE.

- KEY NOTES - RESIDENTIAL - COMMON AREA:**
- FOR CIRCUITING, REFER TO TABLE #1.
  - PROVIDE ALARM SPEAKER SMOKE DETECTOR AND RECEPTACLE AT EVERY THIRD FLOOR CORRIDOR STARTING FROM TOP FLOOR, AS PER TO DUG. E-32 FOR FIRE ALARM RISER DIAGRAM.
  - PROVIDE TELECOMMUNICATION BACKBOARD C/W 15V, 1A, 15A RECEPTACLE AS PER COMMUNICATION RISER DIAGRAM ON DUG. E-31.
  - CONTRACTOR SHALL REFER TO ELECTRICAL SINGLE LINE DIAGRAM ON DUG. E-30 AND SDP RISER ON DUG. E-31 FOR SDP LOCATIONS AND DISTRIBUTION.
  - PROVIDE CONDUIT AS PER RISER DETAIL #9 ON DUG. E-35 FOR TRISORTER CONTROL SYSTEM.
  - REFER TO SUPERVISED VALVE AND FLOW SWITCH SCHEDULE ON DUG. E-33 FOR DETAILS ON TYPICAL FLOORS.
  - EMERGENCY LIGHT FIXTURES IN LOCKERS, STORAGE, GARBAGE, UTILITY AND SERVICE ROOMS SHALL BE CONNECTED TO BOTH NORMAL AND EMERGENCY POWER AS PER DETAIL #1 OF DUG. E-35.
  - ALLOCATE 2, 120V, 15A, CIRCUITS FROM PANEL 'LP-F' FOR MECHANICAL CONTROL, CONTRACTOR COORDINATE WITH DIV. 15 FOR EXACT LOCATION.
  - SWING STAGE WINDOW WASHING TWIST LOCK WITH LOCKOUTS RECEPTACLE 30A, 3P, 120V, 5UIRE (L15-30R).

**HEAT LOSS REPLACEMENT**

CAT #	DESCRIPTION	QUANTITY
PYROTEX	HDPE JACKETED COPPER SHEATHED MI HEATING CABLE (F)	1 EACH
PYROTEX	JUNCTION BOX (3 ENTRY)	1 EACH
DIGITER4	AUTOMATIC SNOW MELTING CONTROLLER 200V/240V	1 EACH
ETI	OVERHEAD SNOW SENSOR	1 EACH
ETI	PAVEMENT MOUNTED SENSOR - (OPTIONAL REPLACEMENT FOR OVERHEAD SENSOR, FOR BETTER SENSING)	0 EACH
SPIC8	SNOW MELT CAUTION SIGN	2 EACH

- NOTES:**
- THE SYSTEM WILL BE PENTAIR, 200V, 3P, 5kW
  - CONTRACTOR TO VERIFY MATERIAL LIST IS SUITABLE FOR THE ACTUAL SITE MEASUREMENTS AND CONDITIONS.
  - ELECTRICAL DIVISION TO COORDINATE WITH LANDSCAPE AND STRUCTURAL DISCIPLINES FOR CONSTRUCTION DETAILS OF POLE BASES.
  - REFER TO ARCHITECTURAL, LANDSCAPE AND INTERIOR DESIGNER DISCIPLINE FOR EXTERIOR LIGHTING LOCATIONS, MOUNTING HEIGHTS AND DIMENSIONS.

**ELECTRICAL LEGEND**

**LIGHTING**

- FLUORESCENT LIGHT FIXTURE, TYPE AS INDICATED
- LIGHT CONNECTED TO EMERGENCY POWER
- CEILING MOUNTED WALL MOUNTED LIGHT FIXTURE, INCREASED LETTER DENOTES TYPE
- POLE MOUNTED LIGHT FIXTURE, INCREASED LETTER DENOTES TYPE
- CAPPED CEILING LIGHT OUTLET
- TRACK LIGHT
- STRIP LIGHT
- UNDER CABINET FLUORESCENT LIGHT FIXTURE
- CEILING MOUNTED WALL MOUNTED EXIT SIGN
- EMERGENCY LIGHT FIXTURE, TYPE AS INDICATED
- EMERGENCY BATTERY PACK
- OCCUPANCY SENSOR POWER PACKS
- SINGLE/DOUBLE POLE SINGLE/DOUBLE THROW TOGGLE SWITCH RESPECTIVELY
- 13"X4"X4" DEDICATED 3-WAY 4-WAY FLOUT LIGHT, DIMMER SWITCHED LIGHT RESPECTIVELY
- MASTER LIGHTING SHUT-OFF SWITCH
- SENSOR WALL SWITCH, FIRE SELF POWERED
- OCCUPANCY SENSOR, CEILING MOUNTED

**POWER**

- REGULAR DUPLEX RECEPTACLE
- DUPLEX RECEPTACLE GROUND FAULT INTERRUPT
- 3-PORT 1-PORT DUPLEX RECEPTACLE
- ANAL RECEPTACLE TYPE AND CONFIGURATION AS SPECIFIED FOR DRIVER
- CONNECTION FOR OVERCOPPER
- ABOVE COUNTER DEVICE
- FLOOR MOUNTED DEVICES
- CEILING MOUNTED DEVICES
- DISCONNECT SWITCH NON-FUSED
- DISCONNECT SWITCH FUSED
- OPERATION STARTER
- FRACTIONAL MOTOR/FAN DIRECT CONNECTION
- DIRECT CONNECTION SINGLE PHASE
- DIRECT CONNECTION THREE PHASE
- THERMOSTAT
- DRYER SENSOR
- ELECTRICAL HEATER
- HEAT TRACE
- SECURITY PANEL / SECURITY PANEL

**TELECOMMUNICATION**

- TELEPHONE OUTLET
- TELEPHONE CABLE (MULTI-PORT OUTLET)
- DATA OUTLET
- DATA/TELEPHONE OUTLET
- SUITE TELECOM BOX C/W RECEPTACLE
- WIFI LOCATION
- VIDEO INTERCOM
- RADIO RECEIVER

**SECURITY**

- INTERCOM / INTERPHONE
- INTERCOM WITH CAMERA
- PANIC BUTTON / PANIC INTERCOM STATION
- CARD READER
- AUTOMATIC RELEASE CARD ACCESS/RADIO RECEIVER
- ELECTRIC STRIKE
- MAGLOCK
- DOOR CONTACT / WINDOW CONTACT
- GLASS BREAK DETECTOR
- AUTOMATIC DOOR OPERATOR
- MOTION DETECTOR
- PUSH BUTTON
- SECURITY CAMERA

**LIFE SAFETY**

- FIRE ALARM SMOKE DETECTOR
- SMOKE ALARM
- FIRE ALARM DUST TYPE SMOKE DETECTOR
- FIRE ALARM HEAT DETECTOR
- FIXED TEMP. 68 °C DEGREE HEAT DETECTOR
- MOISTURE PROOF HEAT DETECTOR
- CO ALARM
- CONCIERGE PHONE 1 CO ALARM
- CO SENSOR / NO SENSOR
- FIRE ALARM MANUAL CALL STATION
- FIREFIGHTER'S HANDSET
- FIRE ALARM SPEAKER/SROBE WALL MTD.
- FIRE ALARM SPEAKER WALL MTD.
- FIRE ALARM SPEAKER/SROBE CEILING MTD.
- FIRE ALARM SPEAKER CEILING MTD.
- FIRE ALARM ANNUNCIATOR PANEL
- FIRE ALARM CONTROL PANEL

**REVISIONS**

NO.	DATE	DESCRIPTION
1		
2		
3		
4		
5		
6		
7		
8		
9		
10		
11		
12		
13		
14		
15		
16		
17		
18		
19		
20		
21		
22		
23		
24		
25		
26		
27		
28		
29		
30		
31		
32		
33		
34		
35		
36		
37		
38		
39		
40		
41		
42		
43		
44		
45		
46		
47		
48		
49		
50		

**NOVA TRENDS**

175 West Beaver Creek Road, Unit 31  
Richmond Hill, Ontario L4B 3M1  
Tel: 905 882-5445  
Fax: 905 882-5441  
Email: cad@novatrendeng.com

**DRAWING TITLE**  
9/F SOUTH FLOOR PLAN  
ELECTRICAL LAYOUT

**PROJECT FILE**  
ALEXANDRA PARK

38 CAMERON STREET, BLOCK II  
TORONTO ONTARIO

**DRAWN BY:** S.O. **CHECKED BY:** S.T. **SCALE:** 1:50  
**DATE:** FEB, 13 **PROJECT NUMBER:** 1313 **DRAWING NUMBER:** E-22