

GENERAL AREA CIRCUITING - TABLE #1

LIGHTING FIXTURE LOCATION	CCT. #
MPH - EXIT SIGNS	E-1
MPH - EXIT SIGNS	E-3
MPH - EXIT SIGNS	ER-1
STAIR 'A' (F2 TO G/F)	E-5
STAIR 'B' (F2 TO G/F)	E-7
STAIR 'U' (G/F TO 4/F)	E-9
STAIR 'U' (G/F TO 3/F)	E-11
STAIR 'G' (G/F TO 14/F)	E-13
STAIR 'F' (G/F TO 14/F)	E-15
STAIR 'K' (14/F TO MPH) 4 MPH (G/F)	ER-3ER-5R-11R-13
(G/F)	E-2E-4E-6E-16E-8E-10E-12E-14E-16
(G/F)	B1-2B1-4B1-6B1-8B1-10B1-12B1-14B1-16B1-18B1-20B1-22B1-24B1-26B1-28B1-30
CORRIDOR (2/F 4 3/F)	E-24
CORRIDOR (4/F 4 5/F)	E-26
CORRIDOR (6/F 4 7/F)	E-28
CORRIDOR (8/F TO 11/F)	E-30
CORRIDOR (12/F TO 14/F)	E-32
CORRIDOR 4 LOCKER (2/F)	B-46
CORRIDOR (3/F)	B-48
CORRIDOR (4/F)	B-50
CORRIDOR (5/F 4 6/F)	B-52
CORRIDOR (7/F 4 8/F)	B-54
CORRIDOR (9/F TO 11/F)	B-56
CORRIDOR (12/F TO 14/F)	B-58
ELEVATOR CAB	ER-6, ER-8ER-10
EXTERIOR SITE	E1-E11-3E1-5E1-7E1-4E1-6
RECEPTACLE LOCATION	CCT. #
ELEC. S. CLOSET (G/F TO 3/F)	B-2
ELEC. N. CLOSET (2/F TO 3/F)	B-4
ELEC. N. CLOSET (10/F TO 14/F)	B-6
ELEC. N. CLOSET (22/F TO 32/F)	B-8
ELEV. LOBBY (F2 TO 8/F)	B-10
CORRIDOR (2/F TO 8/F)	B-12B-14B-16B-18B-20B-22B-24
CORRIDOR (2/F TO 8/F)	B-26B-28
ELEV. LOBBY (9 TO 14/F)	B-30
CORRIDOR (9/F TO 14/F)	B-32B-34B-36B-38
STAIR A (G/F) 4 J/9/F/6/F/3/F)	B-40
STAIR F (14/F) 11/F/8/F/5/F/2/F)	B-42
STAIR H (14/F) 11/F/8/F/5/F/2/F)	B-44
STAIR 'K' 4 MPH	R-2

- KEY NOTES - INSUITE:**
- DESIGNATED "LAUNDRY RECEPTACLE" AS DEFINED BY ESA CODE 26-120(e)(11), 26-120(b) AND ESA BULLETIN 26-26-0 (WITHIN 3m RADIUS OF LAUNDRY CLOSET). RECEPTACLE SHALL BE CONNECTED TO A DEDICATED CIRCUIT. SEE DETAIL #4 ON DWG. E-35.
 - SUITE DOOR CONTACTS AND GLASS BREAK DETECTOR WILL COMPLETE WITH INTRUSION ALARM SYSTEM THAT CONTACT TO THE CONCIERGE STATION. (TYPICAL)
 - FOR FAN COIL UNITS (FCU) ELECTRICAL CONTRACTOR TO SUPPLY AND INSTALL CONDUIT AND JUNCTION BOX FOR REMOTE THERMOSTAT. MECHANICAL CONTRACTOR SHALL SUPPLY, WIRE, TERMINATE WIRING AND MOUNT THERMOSTAT.
 - INSTALL SIDE-MOUNTED RECEPTACLE ON KITCHEN ISLAND CABINET.
 - SWITCHES, RECEPTACLES, ETC. TO BE INSTALLED AS TO NOT INTERFERE WITH THE OPENING AND OPERATION OF SLIDING DOOR.
 - TERRACE LIGHTING FIXTURE AND RECEPTACLE, SHALL BE CENTERED ON PANEL (350MM FROM CENTRE OF DOOR MULLION). REFER TO ARCHITECTURAL ELEVATION.

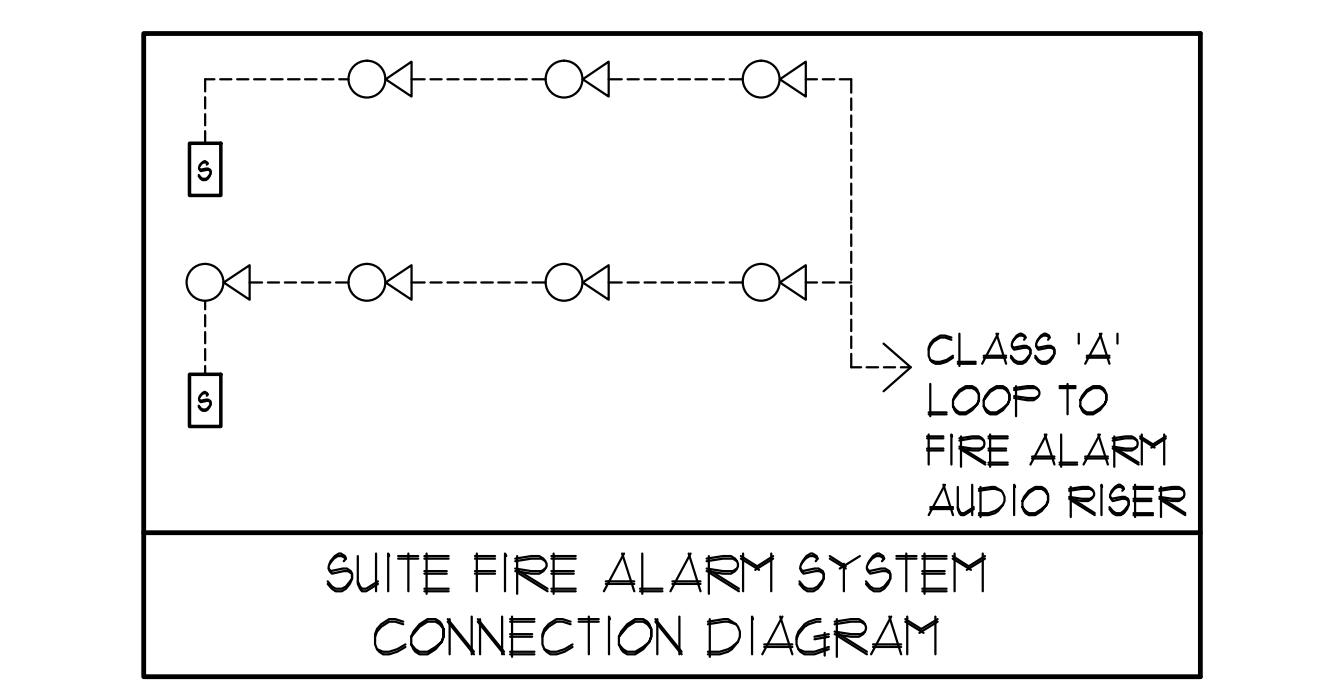

MOUNTING HEIGHT SCHEDULE (TO TOP OF BOX)

OUTLET	SUITES	PUBLIC AREA
RECEPTACLE	400 MM AFF.	400 MM AFF.
TV OUTLET	400 MM AFF.	400 MM AFF.
TELEPHONE OUTLET	400 MM AFF.	400 MM AFF.
MULTI-PORT OUTLET	400 MM AFF.	400 MM AFF.
SWITCH	1200 MM AFF.	1200 MM AFF.
SECURITY PANEL	1200 MM AFF.	
SILENCE SWITCHES	1200 MM AFF.	
THERMOSTAT	1200 MM AFF.	1200 MM AFF.
INTERCOM		1200 MM AFF.
V.C. HANDSET		1200 MM AFF.
FULL STATION		1200 MM AFF.

- GENERAL NOTES - RESIDENTIAL:**
- ELECTRICAL DRAWINGS SHALL BE READ IN CONJUNCTION WITH MECHANICAL, STRUCTURAL, ARCHITECTURAL AND LANDSCAPE DRAWINGS.
 - CONTRACTOR SHALL RUN CABLES WITHIN CEILING SLAB OR ENCLOSURES TO RETAIN 2 HOUR FIRE PROTECTION RATING FOR ALL LOADS THAT CONNECT TO EMERGENCY POWER.
 - FIRE ALARM RISERS SHALL BE RUN IN 2 HOUR FIRE RATED ELECTRICAL CLOSET. REFER TO DWG. E-32 FOR RISER DIAGRAM AND DETAILS.
 - STAIRWAY WALL MOUNTED EMERGENCY LIGHT FIXTURES SHALL BE MOUNTED @ 1" AFF. MIN.
 - FOR STORAGE ROOM VENTILATION SYSTEM, DIV. 16 TO PROVIDE CONDUIT, WIRING AND SWITCH (S) TO START/STOP FAN AND DAMPER. FAN AND 110V ACTUATOR TO BE SUPPLIED AND INSTALLED BY DIV. 15.
 - FOR UTILITY ROOM VENTILATION SYSTEM, DIV. 15 WILL PROVIDE LINE VOLTAGE THERMOSTAT (T) TO DIV. 16. DIV. 16 TO PROVIDE CONDUIT AND WIRING TO START/STOP FAN AND DAMPER VIA THERMOSTAT. FAN AND 110V ACTUATOR TO BE SUPPLIED AND INSTALLED BY DIV. 15.
 - FOR UNIT HEATER, DIV. 15 TO PROVIDE LINE VOLTAGE THERMOSTAT (T), DIV. 16 TO PROVIDE CONDUIT AND WIRING TO START/STOP UNIT HEATER.
 - REFER TO SPRINKLER DRAWINGS FOR FIRE PROTECTION DEVICE TO BE CONNECTED TO THE FIRE ALARM SYSTEM. THE DEVICE AND EQUIPMENT SHALL FORM AN INTEGRAL PART OF THE ELECTRICAL CONTRACT.
 - DIV. 16 SHALL SUPPLY AND INSTALL CONDUITS, WIRES AND INTERLOCK FANS TO MOTORIZED DAMPERS AND TO THE THERMOSTAT.
 - DIV. 16 SHALL SUPPLY AND INSTALL CONDUITS, WIRES AND INTERLOCK FANS TO MOTORIZED DAMPERS AND TO THE THERMOSTAT.
 - REFER TO SUITE PANEL SCHEDULES FOR INSUITE CIRCUIT ARRANGEMENT.
 - ALL DWELLING UNIT RECEPTACLES EXCEPT IN KITCHEN SHALL BE TAMPER PROOF.
 - PROVIDE GROUND FAULT PROTECTION FOR SUITE KITCHEN, AMENITY KITCHEN AND WASHROOM RECEPTACLES WITHIN 1500mm OF SINK.
 - PROVIDE TELECOMMUNICATION BOX C/W BUILT-IN RECEPTACLE FOR TELECOMMUNICATION. TELECOMMUNICATION BOX SHALL BE COMPLIANT WITH THE TELECOM SERVICE PROVIDER SPECIFICATION. REFER TO DETAIL #9 ON DWG. E-35 FOR TELECOM JUNCTION BOX INSTALLATION.
 - DRYER SENSOR TO START DRYER VENTILATION FAN AUTOMATICALLY WHEN DRYER IS RUNNING.
 - ALL SMOKE ALARMS WITHIN THE SUITE SHALL BE HARDWIRED TOGETHER AND TO A 15A, 1P CIRCUIT BREAKER AHEAD OF OTHER LOADS.
 - ALL OUTDOOR RECEPTACLES SHALL BE WEATHERPROOF (LEGRANDE CAT# 3232TRUR-GRY FOR NON-GFCI AND CAT# 1893TRUR-GRY FOR GFCI) AND SHALL BE EQUIPPED WITH A WHILE IN USE CAST ALUMINUM COVERPLATE (LEGRANDE CAT# WUCASTI) COVERPLATE.

- KEY NOTES - RESIDENTIAL - COMMON AREA:**
- FOR CIRCUITING, REFER TO TABLE #1.
 - PROVIDE ALARM SPEAKER, SMOKE DETECTOR AND RECEPTACLE AT EVERY THIRD FLOOR STAIR WELL STARTING FROM TOP FLOOR. AS PER TO DWG. E-32 FOR FIRE ALARM RISER DIAGRAM.
 - PROVIDE TELECOMMUNICATION BACKBOARD C/W 15V, 1P 15A RECEPTACLE AS PER COMMUNICATION RISER DIAGRAM ON DWG. E-31.
 - CONTRACTOR SHALL REFER TO ELECTRICAL SINGLE LINE DIAGRAM ON DWG. E-30 AND SDP RISER ON DWG. E-31 FOR SDP LOCATIONS AND DISTRIBUTION.
 - PROVIDE CONDUIT AS PER RISER DETAIL #9 ON DWG. E-35 FOR TRISORTER CONTROL SYSTEM.
 - REFER TO SUPERVISED VALVE AND FLOW SWITCH SCHEDULE ON DWG. E-33 FOR DETAILS ON TYPICAL FLOORS.

ELECTRICAL LEGEND

LIGHTING

- FLUORESCENT LIGHT FIXTURE, TYPE AS INDICATED
- LIGHT CONNECTED TO EMERGENCY POWER
- CEILING MOUNTED WALL MOUNTED LIGHT FIXTURE, INCREASED LETTER DENOTES TYPE
- POLE MOUNTED LIGHT FIXTURE, INCREASED LETTER DENOTES TYPE
- CARRIED CEILING LIGHT OUTLET
- TRACK LIGHT
- STRIP LIGHT
- UNDER CABINET FLUORESCENT LIGHT FIXTURE
- CEILING MOUNTED WALL MOUNTED EXIT SIGN
- RECYCLED EMERGENCY LIGHT REFLECTOR HEAD
- EMERGENCY BATTERY PACK
- OCCUPANCY SENSOR POWER PACKS
- SINGLE/DOUBLE/TREE POLE SINGLE/DOUBLE/TREE TRIMMABLE TOGGLE SWITCH RESPECTIVELY
- 1/4" / 3/4" / 1" / 1 1/2" / 2" / 3" / 4" / 6" / 8" / 10" / 12" / 14" / 16" / 18" / 20" / 24" / 30" / 36" / 42" / 48" / 54" / 60" / 66" / 72" / 78" / 84" / 90" / 96" / 102" / 108" / 114" / 120" / 126" / 132" / 138" / 144" / 150" / 156" / 162" / 168" / 174" / 180" / 186" / 192" / 198" / 204" / 210" / 216" / 222" / 228" / 234" / 240" / 246" / 252" / 258" / 264" / 270" / 276" / 282" / 288" / 294" / 300" / 306" / 312" / 318" / 324" / 330" / 336" / 342" / 348" / 354" / 360" / 366" / 372" / 378" / 384" / 390" / 396" / 402" / 408" / 414" / 420" / 426" / 432" / 438" / 444" / 450" / 456" / 462" / 468" / 474" / 480" / 486" / 492" / 498" / 504" / 510" / 516" / 522" / 528" / 534" / 540" / 546" / 552" / 558" / 564" / 570" / 576" / 582" / 588" / 594" / 600" / 606" / 612" / 618" / 624" / 630" / 636" / 642" / 648" / 654" / 660" / 666" / 672" / 678" / 684" / 690" / 696" / 702" / 708" / 714" / 720" / 726" / 732" / 738" / 744" / 750" / 756" / 762" / 768" / 774" / 780" / 786" / 792" / 798" / 804" / 810" / 816" / 822" / 828" / 834" / 840" / 846" / 852" / 858" / 864" / 870" / 876" / 882" / 888" / 894" / 900" / 906" / 912" / 918" / 924" / 930" / 936" / 942" / 948" / 954" / 960" / 966" / 972" / 978" / 984" / 990" / 996" / 1002" / 1008" / 1014" / 1020" / 1026" / 1032" / 1038" / 1044" / 1050" / 1056" / 1062" / 1068" / 1074" / 1080" / 1086" / 1092" / 1098" / 1104" / 1110" / 1116" / 1122" / 1128" / 1134" / 1140" / 1146" / 1152" / 1158" / 1164" / 1170" / 1176" / 1182" / 1188" / 1194" / 1200

POWER

- REGULAR DUPLEX RECEPTACLE
- DUPLEX RECEPTACLE, GROUND FAULT INTERRUPT
- 3-PORT T-PORT DUPLEX RECEPTACLE
- SINGLE RECEPTACLE TYPE AND CONFIGURATION AS SPECIFIED FOR DRIVER
- CONNECTION FOR OVEN/COOKTOP
- MOVIE COUNTER DEVICE
- FLOOR MOUNTED DEVICES
- DISCONNECT SWITCH, NON-FUSED
- DISCONNECT SWITCH, FUSED
- GENERATION STARTER
- FRACTIONAL MOTOR/FAN DIRECT CONNECTION
- DIRECT CONNECTION SINGLE PHASE
- DIRECT CONNECTION THREE PHASE
- THERMOSTAT
- DRYER SENSOR
- HEAT TRACE
- ELECTRICAL HEATER
- ELECTRICAL PANEL / SECURITY PANEL

TELECOMMUNICATION

- TELEPHONE OUTLET
- TELEPHONE / CABLE (MULTI-PORT) OUTLET
- DATA OUTLET
- DATA/TELEPHONE OUTLET
- IN SUITE TELECOM BOX C/W RECEPTACLE
- WIFI LOCATION
- VIDEO INTERCOM
- RADIO RECEIVER

SECURITY

- INTERCOM / INTERPHONE
- INTERCOM WITH CAMERA
- PANIC BUTTON / PANIC INTERCOM STATION
- CARD READER
- AUTOMATIC RELEASE CARD ACCESS/RADIO RECEIVER
- ELECTRIC STRIKE
- MAGLOCK
- DOOR CONTACT / WINDOW CONTACT
- GLASS BREAK DETECTOR
- AUTOMATIC DOOR OPERATOR
- MOTION DETECTOR
- PUSH BUTTON
- SECURITY CAMERA

LIFE SAFETY

- FIRE ALARM SMOKE DETECTOR
- SMOKE ALARM
- FIRE ALARM DUCT TYPE SMOKE DETECTOR
- FIRE ALARM HEAT DETECTOR
- FIXED TEMP. 68 °C DEGREE HEAT DETECTOR
- MOISTURE PROOF HEAT DETECTOR
- CO ALARM
- COMBINATION SMOKE 4 CO ALARM
- CO SENSOR / NO SENSOR
- FIRE ALARM MANUAL PULL STATION
- FIREFIGHTER'S HANDSET
- FIRE ALARM SPEAKER/STROBE WALL MTD.
- FIRE ALARM SPEAKER WALL MTD.
- FIRE ALARM SPEAKER/STROBE CEILING MTD.
- FIRE ALARM SPEAKER CEILING MTD.
- FIRE ALARM ANNUNCIATOR PANEL
- FIRE ALARM CONTROL PANEL

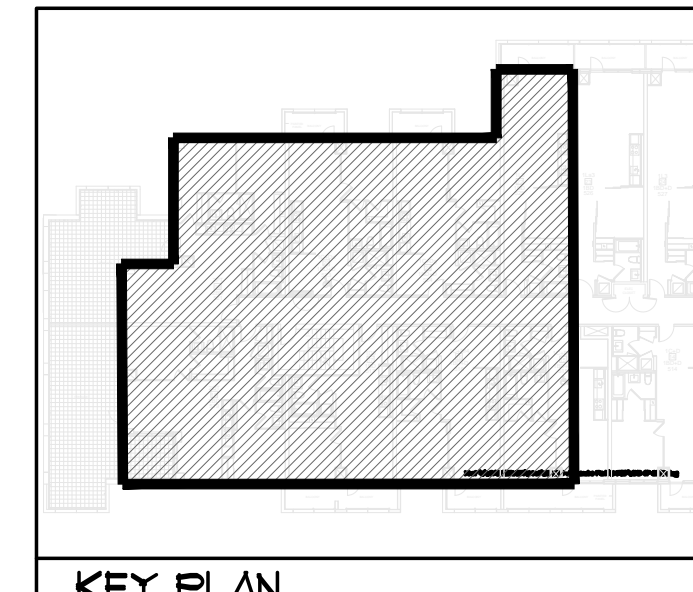

NOVA TRENDS

175 West Beaver Creek Road, Unit 31
Richmond Hill, Ontario L4B 3M1
Tel: 905-882-5445
Fax: 905-882-5441
Email: cad@novatrendeng.com

REVISIONS

NO.	DATE	DESCRIPTION
01		ISSUED FOR PERMIT
02		ISSUED FOR PERMIT
03		ISSUED FOR PERMIT
04		ISSUED FOR PERMIT
05		ISSUED FOR PERMIT
06		ISSUED FOR PERMIT
07		ISSUED FOR PERMIT
08		ISSUED FOR PERMIT
09		ISSUED FOR PERMIT
10		ISSUED FOR PERMIT
11		ISSUED FOR PERMIT
12		ISSUED FOR PERMIT
13		ISSUED FOR PERMIT
14		ISSUED FOR PERMIT
15		ISSUED FOR PERMIT
16		ISSUED FOR PERMIT
17		ISSUED FOR PERMIT
18		ISSUED FOR PERMIT
19		ISSUED FOR PERMIT
20		ISSUED FOR PERMIT
21		ISSUED FOR PERMIT
22		ISSUED FOR PERMIT
23		ISSUED FOR PERMIT
24		ISSUED FOR PERMIT
25		ISSUED FOR PERMIT
26		ISSUED FOR PERMIT
27		ISSUED FOR PERMIT
28		ISSUED FOR PERMIT
29		ISSUED FOR PERMIT
30		ISSUED FOR PERMIT
31		ISSUED FOR PERMIT
32		ISSUED FOR PERMIT
33		ISSUED FOR PERMIT
34		ISSUED FOR PERMIT
35		ISSUED FOR PERMIT
36		ISSUED FOR PERMIT
37		ISSUED FOR PERMIT
38		ISSUED FOR PERMIT
39		ISSUED FOR PERMIT
40		ISSUED FOR PERMIT
41		ISSUED FOR PERMIT
42		ISSUED FOR PERMIT
43		ISSUED FOR PERMIT
44		ISSUED FOR PERMIT
45		ISSUED FOR PERMIT
46		ISSUED FOR PERMIT
47		ISSUED FOR PERMIT
48		ISSUED FOR PERMIT
49		ISSUED FOR PERMIT
50		ISSUED FOR PERMIT
51		ISSUED FOR PERMIT
52		ISSUED FOR PERMIT
53		ISSUED FOR PERMIT
54		ISSUED FOR PERMIT
55		ISSUED FOR PERMIT
56		ISSUED FOR PERMIT
57		ISSUED FOR PERMIT
58		ISSUED FOR PERMIT
59		ISSUED FOR PERMIT
60		ISSUED FOR PERMIT
61		ISSUED FOR PERMIT
62		ISSUED FOR PERMIT
63		ISSUED FOR PERMIT
64		ISSUED FOR PERMIT
65		ISSUED FOR PERMIT
66		ISSUED FOR PERMIT
67		ISSUED FOR PERMIT
68		ISSUED FOR PERMIT
69		ISSUED FOR PERMIT
70		ISSUED FOR PERMIT
71		ISSUED FOR PERMIT
72		ISSUED FOR PERMIT
73		ISSUED FOR PERMIT
74		ISSUED FOR PERMIT
75		ISSUED FOR PERMIT
76		ISSUED FOR PERMIT
77		ISSUED FOR PERMIT
78		ISSUED FOR PERMIT
79		ISSUED FOR PERMIT
80		ISSUED FOR PERMIT
81		ISSUED FOR PERMIT
82		ISSUED FOR PERMIT
83		ISSUED FOR PERMIT
84		ISSUED FOR PERMIT
85		ISSUED FOR PERMIT
86		ISSUED FOR PERMIT
87		ISSUED FOR PERMIT
88		ISSUED FOR PERMIT
89		ISSUED FOR PERMIT
90		ISSUED FOR PERMIT
91		ISSUED FOR PERMIT
92		ISSUED FOR PERMIT
93		ISSUED FOR PERMIT
94		ISSUED FOR PERMIT
95		ISSUED FOR PERMIT
96		ISSUED FOR PERMIT
97		ISSUED FOR PERMIT
98		ISSUED FOR PERMIT
99		ISSUED FOR PERMIT
100		ISSUED FOR PERMIT

CONTRACTOR MUST CHECK AND VERIFY ALL DIMENSIONS AND CONDITIONS BEFORE PROCEEDING WITH THE WORK. THIS DRAWING IS THE PROPERTY OF THE ENGINEER AND WILL BE RETURNED UPON COMPLETION OF THE WORK.

DRAWINGS ARE NOT TO BE SCALED

NOVA TRENDS

175 West Beaver Creek Road, Unit 31
Richmond Hill, Ontario L4B 3M1
Tel: 905-882-5445
Fax: 905-882-5441
Email: cad@novatrendeng.com

PROJECT FILE
ALEXANDRA PARK
38 CAMERON STREET, BLOCK II
TORONTO ONTARIO

DRAWING TITLE
5/F SOUTH FLOOR PLAN
ELECTRICAL LAYOUT

DRAWN BY S.O. **CHECKED BY** S.T. **SCALE** 1:50

DATE FEB, 13 **PROJECT NUMBER** 1313 **DRAWING NUMBER** E-14